

# GC8700 Series



### FEATURES & OPTIONS

- UL Listed (UL 10C)
- Universal application and non-handed installation (regular and parallel bracket included)
- Multi-size strength, power adjustable
  - GC8700, size 3-6. Factory preset size 3
  - GC8700BF, size 1-4. Factory preset size 2
- Hardened steel rack and pinion mechanism
- Adjustable back check standard
- Fixing for both metal and timber doors
- Adjustable closing and latching speed
- Optional barrier free
- Door weight range from 88 ~ 265 lbs for GC8700 and 44 ~ 187 lbs for GC8700BF
- Stable hydraulic fluid capable of withstanding temperature ranges of 105 degrees F. to -25 degrees F
- Application: Surface door closer for interior and exterior doors with flexibility to meet most common commercial footprint

### PACKAGE INCLUDES

- Parallel bracket
- Wood screws and machine screws
- Full plastic cover
- Sex bolts and Thru bolts

### FINISHES

- Aluminum (painted)
- Dark Brown (painted)
- Gold Brass (painted)
- Matte Black (painted)

### WARRANTY

- 25 years mechanical warranty
- Five years finish warranty



### CODE COMPLIANCE

- ANSI A156.4 Grade 1
- UL10C and UBC 7.2 for positive pressure
- Meets ADA barrier-free accessibility

### SPECIFICATIONS

**Closer:** Closers shall be by Pamex model # GC8700, full rack and pinion type with cast aluminum alloy body. All closers shall be provided with non-critical valves adjustment to independently regulate the sweep, latch and back-check. Closer shall have full spring adjustment from size 1 to 4 for barrier free (BF).

### APPLICATION

Surface door closer for interior and exterior doors with flexibility to meet most common commercial footprint

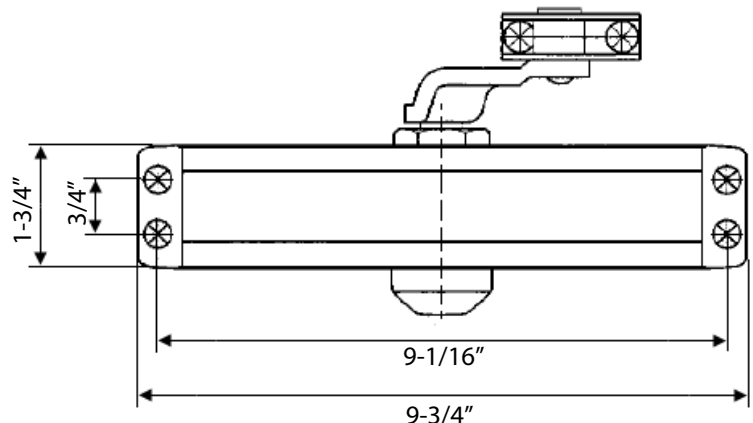

# GC8716 Series



### FEATURES & OPTIONS

- UL Listed (UL 10C)
- Universal application and non-handed installation (regular and parallel bracket included)
- Multi-size strength, power adjustable, size 1-6
- Hardened steel rack and pinion mechanism
- Adjustable back check standard
- Fixing for both metal and timber doors
- Adjustable closing and latching speed
- Optional barrier free
- Door weight range from 44 ~ 265 lbs
- Stable hydraulic fluid capable of withstanding temperature ranges of 105 degrees F. to -25 degrees F.

### PACKAGE INCLUDES

- Parallel bracket
- Wood screws and machine screws
- Full plastic cover
- Sex bolts and Thru bolts

### FINISHES

- Aluminum (painted)
- Dark Brown (painted)
- Matte Black (painted)

### WARRANTY

- 25 years mechanical warranty
- Five years finish warranty



### CODE COMPLIANCE

- ANSI A156.4 Grade 1
- UL10C and UBC 7.2 for positive pressure
- Meets ADA barrier-free accessibility

### SPECIFICATIONS

**Closer:** Closers shall be by Pamex model # GC8700, full rack and pinion type with cast aluminum alloy body. All closers shall be provided with non-critical valves adjustment to independently regulate the sweep, latch and back-check. Closer shall have full spring adjustment from size 1 to 6 for barrier free (BF).

### APPLICATION

Surface door closer for interior and exterior doors with flexibility to meet most common commercial footprint

