

INSTALLATION INSTRUCTIONS FOR NON-FIRE & FIRE RATED REMOVABLE MULLION

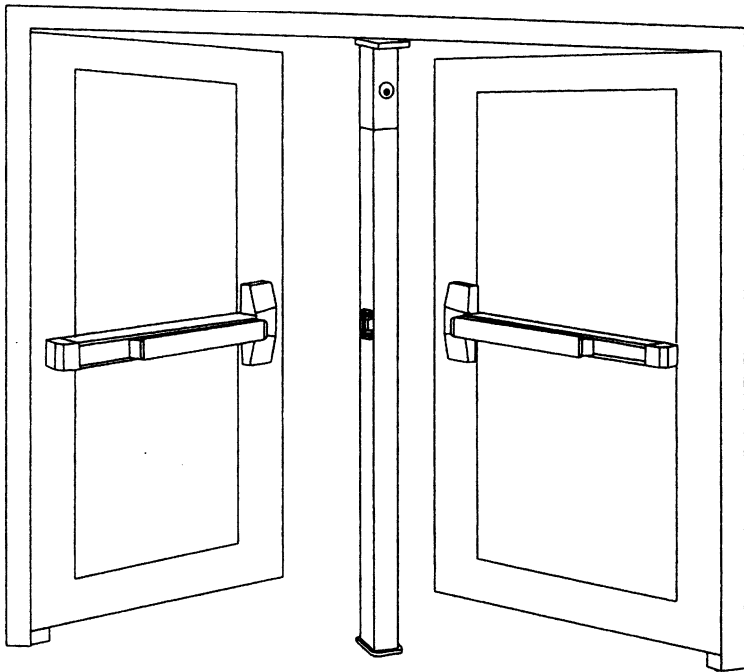

The removable Mullion is used for with two Rim Devices on double doors.

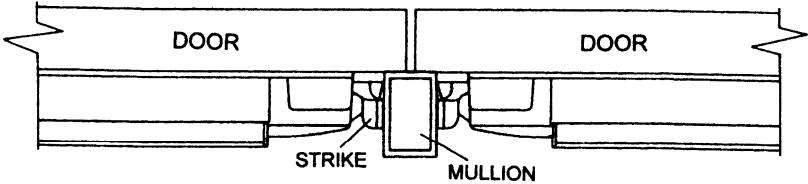

STEP 1 : MARK CENTERS & HOLE LOCATIONS

1. Mark the center of the width of the door opening at the soffit and at the floor. (See Fig. 1)
2. As shown in Fig. 2, mark a centerline of the width of the Top Bracket edge. Then place the top bracket at the soffit of the top frame and align the centerline with the mark that you made in Step 1-1. Close the doors and butt the centerline side to the doors. Make sure the centerline on the top bracket is in alignment with the gap of the two single doors.
3. Mark and drill four (4) hole locations on the soffit using the Top Bracket as a template. Tap the four (4) holes with 5/16 -18 thread. [J size (0.277") pilot holes are recommended.]

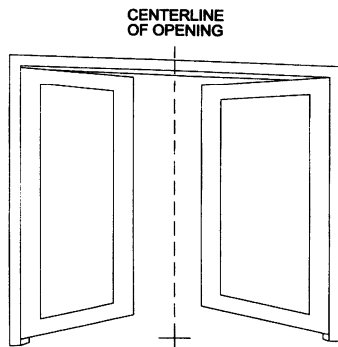
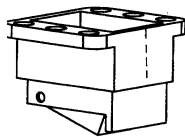

Fig. 1



Mark a centerline on Top Bracket

Fig. 2

STEP 2 : INSTALL TOP BRACKET

1. Tighten the top bracket to the soffit with the fixing screws (5/16-18 x 5/8") provided. (See Fig. 3)

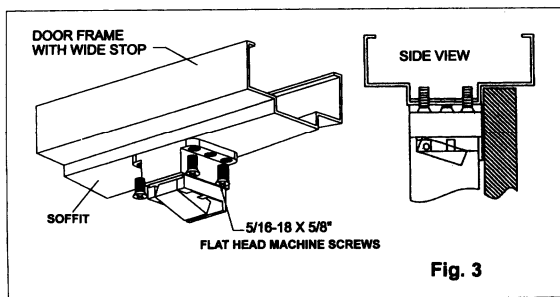

Fig. 3

2. If the top bracket is installed on a typical door frame (with a narrow stop), the top bracket overhangs the stop, the furnished shims should be used, see Fig. 4.
 - a. Check stop height and match to shims (1/2" or 5/8").
 - b. Install shims using the long screws (5/16-18x1-1/2" flat countersunk head) supplied in the hardware kit.

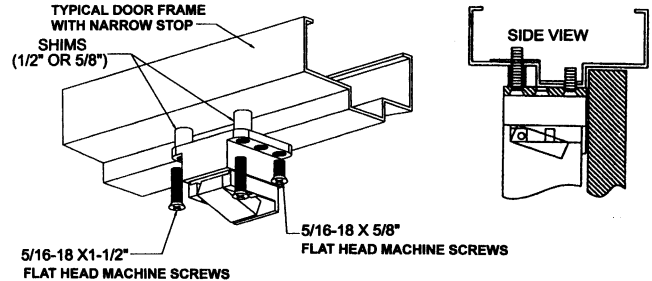

Fig. 4

STEP 3 : INSTALL BOTTOM BRACKET

1. If there is a threshold, be sure to cut it, so that the bottom bracket can be installed flush on the floor.
2. Place the mullion tube first into the bottom bracket, then into the top bracket. Close the door again. Move the bottom bracket at floor slightly and butt the mullion to the doors. Align centering notches on the bracket with the mark that you made in Step 1-1. Mark and drill four (4) holes on the floor for anchors. (For Non-Fire Rated Devices: 1/2" x 1" deep. For Fire Rated Devices: 1/2" x 1-3/4" deep.) Tighten the bottom bracket to the floor with the anchors and bolts provided. (See Fig. 5)

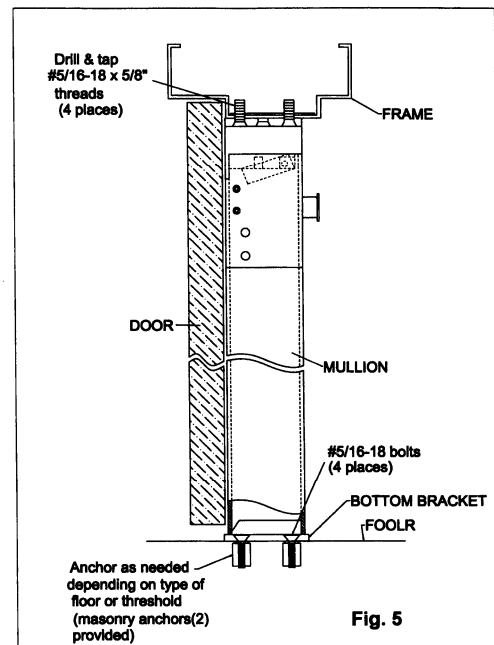
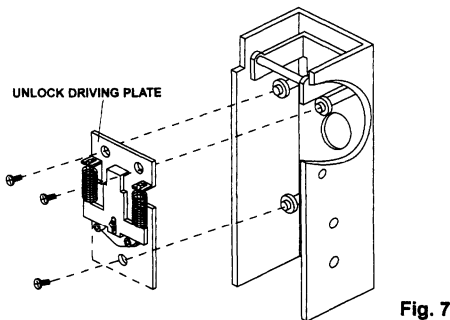
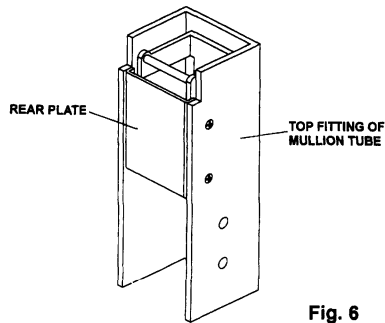

Fig. 5

STEP 4 : INSTALL CYLINDER

If the mullion already has a cylinder installed, skip this step. If the mullion does not have a cylinder installed, follow the procedure below:

1. Remove the Rear Plate by removing the 4 attachment screws (see Fig. 6). Now remove the Unlock Driving Plate by removing its 3 attachment screws. (See Fig. 7).



4. Place and fasten the unlock driving plate and the rear plate back in place. (See Fig. 9)

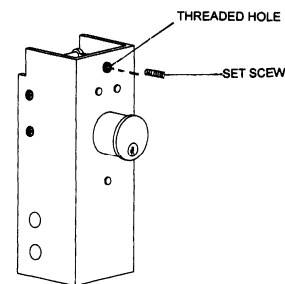
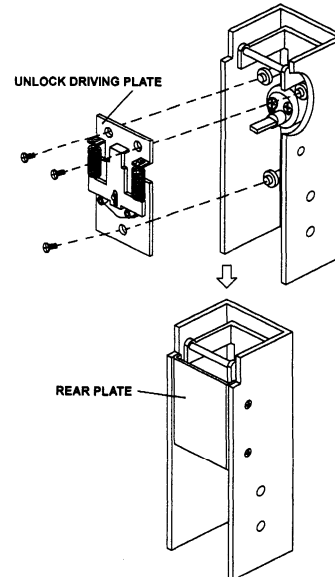

2. Slide cylinder collar onto the rim cylinder body, then install a cylinder mounting cup on the back side of the top fitting.
3. Install the rim cylinder into the top fitting, and align the tailpiece and tailpiece hole on the cylinder cup then let the end of tailpiece go through the hole. Adjust and cut break-off screws and the tailpiece to eliminate excess length and secure the rim cylinder. (See Fig. 8)

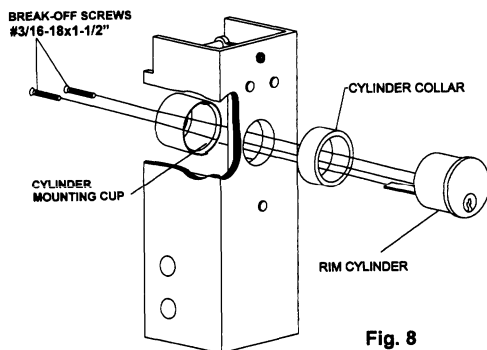

STEP 5 : INSTALL MULLION TUBE

1. Measure the distance from the soffit to the floor shown as "H" in Fig. 10. Then subtract 1-7/8" (47.5mm) from the measurement that is the actual length you need to use, shown as "C" in Fig. 10.
2. Mark a cutting line on the bottom end of the mullion tube then cut the excess portion.
3. Place the mullion tube into the bottom bracket and the top bracket. Make sure the mullion tube can snap firmly into place. If the mullion tube is cut too short, shim plates should be used to raise the bottom bracket. NOTE: They are not included in the installation kits and are ordered separately.
4. Ensure that the mullion is easily removable when the key is turned.
5. To take out any movement in the mullion, once it's installed, tighten the set screw in the threaded hole with the hex key provided in the Installation Kit. (See Fig. 9)

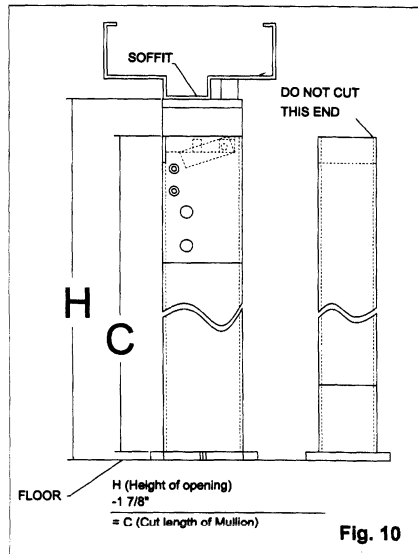

Fig. 10

STEP 6 : INSTALL STRIKES AND RIM EXIT DEVICES

1. For the Non-Fire Rated Keyed Removable Mullion
Install rim strikes on both sides of the mullion as per the template and the installation instructions of the rim exit device.
2. For the Fire Rated Keyed Removable Mullion
Use the provided instructions of mullion strike and strike hook to install them on the mullion and each door leaf. Ensure that the strike hook engages the strike without interference to the latching mechanism. Open and close the door to ensure the correct installation. The strike hook should not cause friction or bind during the opening and closing cycles of the door.